

Vakuum-Lösungen

Applikations-  
Unterstützung

Service



LEYBOLD VAKUUM

KA 01.692/4



## **Komplett - Set zur TRIVAC E**

**D 1,2 E - D 2,5 E**

### **Komplett-Set für:**

- Ölabscheidung (Formfilter)
- Abdichtung komplett
- Verschleißteile

---

## **Complete Kit for TRIVAC E**

**D 1.2 E - D 2.5 E**

### **Complete Kit for:**

- Oil separator  
(internal demister)
- All seals
- Wearing parts

**Kurzanleitung**

**Brief Instructions**

		D1.2E		
Component Item Number	Component Item Description	20040025KIT		
		Qty	Fig. No.	Item No.
320117	O'RING,VITON,92X3 MM	1	1	1
360051	COUPLER,SLEEVE,VITON	2	1	2
23963115	O'RING,VITON,38 X 3 MM	1	1	4
440023	RING,SPACER,STL.,35X29X1MM	1	1	5
310047	SEAL,SHAFT,LIP,W/ DUST LIP	1	1	6
200090	ROTOR,OIL PUMP	1	1	11
580038	VALVE,STOPPER,STEEL	1	1	12
490021	SPRING,COMPRESSION,STEEL	1	1	13
400063	SCREW,SHCS,M5X20MM,S/S	4	2	1
420033	WASHER,FLAT,M5,S/S	6	2	2
P23955165	GASKET,RING,VITON	2	2	3
300046	GASKET,RING,VITON,22X27X2MM	2	2	5
720010	FILTER,DEMISTER	1	2	14
400065	SCREW,SHCS,FLAT HD,M5X6MM,STL.	1	2	21
580037	VALVE,HOLDER,S/S	1	2	22
490020	RETAINER,RESTRICTOR,SPRING	1	2	23
490022	SPRING,COMPRESSION,STEEL	1	2	24
580032	VALVE,NIB,SEALING ELEM.,VITON	1	2	25
580034	VALVE,BRACKET,S/S	1	2	26
40050135	VALVE	1	2	27
400064	SCREW,SHCS,M5X10MM,S/S	2	2	34
420033	WASHER,FLAT,M5,S/S	6	2	35
300044	GASKET,SIGHT GLASS,VITON	1	2	38
300049	GASKET,OIL BOX,VITON	1	2	39
P23955165	GASKET,RING,VITON	2	2	41
23970120	O'RING,VITON,37 X 3 MM	1	3	2
P23955165	GASKET,RING,VITON	2	3	2
23973146	SEAL,FLOAT,VITON	1	3	4
310048	SEAL,SHAFT,LIP,W/O DUST LIP	1	3	6
300047	GASKET,FLAT SEAL,VITON	1	3	7
580033	VALVE,TANDEM,STEEL	1	3	8
490023	SPRING,COMPRESSION,STEEL	1	3	9
580036	VALVE,SPACER,S/S	1	3	10
300046	GASKET,RING,VITON,22X27X2MM	2	3	12
230046G	VANE,G11,1ST STAGE,HV	2	3	16
450031	PIN,VANE,GUIDE,S/S	1	3	17
490024	SPRING,COMPRESSION,STEEL	2	3	18
230047G	VANE,G11,2ND STAGE,LV,FV VANE	2	3	19
450030	PIN,VANE,GUIDE,S/S	1	3	20
400061	SCREW,SHCS,M5X65MM,S/S	2	3	21

		D2.5E		
Component Item Number	Component Item Description	20040026KIT		
		Qty	Fig. No.	Item No.
320117	O'RING,VITON,92X3 MM	1	1	1
360051	COUPLER,SLEEVE,VITON	2	1	2
23963115	O'RING,VITON,38 X 3 MM	1	1	4
440023	RING,SPACER,STL.,35X29X1MM	1	1	5
310047	SEAL,SHAFT,LIP,W/ DUST LIP	1	1	6
200090	ROTOR,OIL PUMP	1	1	11
580038	VALVE,STOPPER,STEEL	1	1	12
490021	SPRING,COMPRESSION,STEEL	1	1	13
400063	SCREW,SHCS,M5X20MM,S/S	4	2	1
420033	WASHER,FLAT,M5,S/S	6	2	2
P23955165	GASKET,RING,VITON	3	2	3
300046	GASKET,RING,VITON,22X27X2MM	2	2	5
400062	SCREW,SHCS,M5X40MM,S/S	1	2	8
640013	INSERT,TUBE,VITON	4	2	9
720010	FILTER,DEMISTER	1	2	14
440022	RING,SPACER,ALUM,11.5X8X1MM	1	2	17
300045	GASKET,RING,VITON,17X22X1.5MM	1	2	20
400065	SCREW,SHCS,FLAT HD,M5X6MM,STL.	1	2	21
580037	VALVE,HOLDER,S/S	1	2	22
490020	RETAINER,RESTRICTOR,SPRING	1	2	23
490022	SPRING,COMPRESSION,STEEL	1	2	24
580032	VALVE,NIB,SEALING ELEM.,VITON	1	2	25
580034	VALVE,BRACKET,S/S	1	2	26
40050135	VALVE	1	2	27
490026	SPRING,COMPRESSION,CONICAL,S/S	1	2	29
34861028	VALVE,NON-RETURN	1	2	30
420032	WASHER,ORFICE,G.B.,S/S	1	2	31
23970436	O'RING,VITON,27 X 2.5 MM	1	2	32
400064	SCREW,SHCS,M5X10MM,S/S	2	2	34
420033	WASHER,FLAT,M5,S/S	6	2	35
300044	GASKET,SIGHT GLASS,VITON	1	2	38
300049	GASKET,OIL BOX,VITON	1	2	39
P23955165	GASKET,RING,VITON	3	2	41
P23955165	GASKET,RING,VITON	3	2	43
23970120	O'RING,VITON,37 X 3 MM	1	3	2
23973146	SEAL,FLOAT,VITON	1	3	4
310048	SEAL,SHAFT,LIP,W/O DUST LIP	1	3	6
300047	GASKET,FLAT SEAL,VITON	1	3	7
580033	VALVE,TANDEM,STEEL	1	3	8
490023	SPRING,COMPRESSION,STEEL	1	3	9
580036	VALVE,SPACER,S/S	1	3	10
300046	GASKET,RING,VITON,22X27X2MM	2	3	12
230048G	VANE,G11,1ST STAGE,HV	2	3	16
450031	PIN,VANE,GUIDE,S/S	1	3	17
490024	SPRING,COMPRESSION,STEEL	2	3	18
230047G	VANE,G11,2ND STAGE,LV,FV VANE	2	3	19
450030	PIN,VANE,GUIDE,S/S	1	3	20
400061	SCREW,SHCS,M5X65MM,S/S	2	3	21

Ref. No. for the complete kits	Type of pump
200 40 025	D 1.2 E

This complete kit contains the following parts:

Fig. 1 / Page 22

Item	Qty.	Designation
1	1	O-ring (92x3)
2	2	Coupling sleeves
4	1	O-ring (38x3)
5	1	Spacing disk
6	1	Shaft sealing ring with dust lip (25x34x6)
11	1	Oil pump
12	1	Stopper
13	1	Compression spring (0,63x3,55x22)

Fig. 2 / Page 23

Item	Qty.	Designation
1	4	Hex. socket bolt (M 5 x 20)
2	4	Washer
3	1	Sealing ring (15,1x22x2)
5	1	Sealing ring (22x27x2)
14	1	Internal demister
21	1	Hex. socket bolt (M 5 x 6)
22	1	Valve holder
23	1	Stroke restrictor
24	1	Compression spring (0,6x7,95x17,3)
25	1	Sealing element
26	1	Valve bracket
27	1	Bypass valve
34	2	Cylinder head screw (M5x10)
35	2	Washer
38	1	Contoured seal (oil level glass)
39	1	Contoured seal (oil box)
41	1	Sealing ring (15,1x22x2)

Fig. 3 / Page 24

Item	Qty.	Designation
2	1	O-ring (36x3)
4	1	Sealing nipple
6	1	Shaft sealing ring without dust lip (18x28x7)
7	1	Flat seal
8	1	Tandem valve
9	1	Compression spring (0,75x4,55x25)
10	1	Spacer
12	1	Sealing ring (22x27x2)
16	2	High vacuum vane
17	1	Guide pin
18	2	Compression spring (0,4x2,4x14,9)
19	2	Forevacuum vane
20	1	Guide pin
21	2	Hex. socket bolt (M5x65)

Ref. No. for the complete kits	Type of pump
200 40 026	D 2.5 E

This complete kit contains the following parts:

Fig. 1 / Page 22

Item	Qty.	Designation
1	1	O-ring (92x3)
2	2	Coupling sleeves
4	1	O-ring (38x3)
5	1	Spacing disk
6	1	Shaft sealing ring with dust lip (25x34x6)
11	1	Oil pump
12	1	Stopper
13	1	Compression spring (0,63x3,55x22)

Fig. 2 / Page 23

Item	Qty.	Designation
1	4	Hex. socket bolt (M 5 x 20)
2	4	Washer
3	1	Sealing ring (15,1x22x2)
5	1	Sealing ring (22x27x2)
8	1	Hex. socket bolt (M 5 x 40)
9	4	Rubber insert
14	1	Internal demister
17	1	Flat seal, Alu (8x11,5x1)
20	1	Flat seal (17x22x1,5) <i>AVBAC</i>
21	1	Hex. socket bolt (M 5 x 6)
22	1	Valve holder
23	1	Stroke restrictor
24	1	Compression spring (0,6x7,95x17,3)
25	1	Sealing element
26	1	Valve bracket
27	1	Bypass valve
29	1	Compression spring (conical)
30	1	Non-return valve
31	1	GB orifice
32	1	O-ring (27 x 2,5)
34	2	Cylinder head bolt (M5x10)
35	2	Washer
38	1	Contoured seal (oil level glass)
39	1	Contoured seal (oil box)
41	1	Sealing ring (15,1x22x2)
43	1	Sealing ring (15,1x22x2)

Fig. 3 / Page 24

Item	Qty.	Designation
2	1	O-ring (36x3)
4	1	Sealing nipple
6	1	Shaft sealing ring without dust lip (18x28x7)
7	1	Flat seal
8	1	Tandem valve
9	1	Compression spring (0,75x4,55x25)
10	1	Spacer
12	1	Sealing ring (22x27x2)
16	2	High vacuum vane
17	1	Guide pin
18	2	Compression spring (0,4x2,4x14,9)
19	2	Forevacuum vane
20	1	Guide pin
21	2	Hex. socket bolt (M5x65)

**Required tools:**

Spanner size 8, securing ring pliers, Hex. socket screw key 4, 6, 8, as well as special tool (200 02 760) for tie rods.  
Shaft sealing ring driver - see sketch.

# 1 Disassembly

**Caution** Before starting work on the pump make sure that the pump is cold.

**Warning** Before starting work on the pump be sure to always disconnect the motor from the mains power. Remove the mains connection (three-phase motors) or pull the mains plug.



## 1.1 Disassembly of the Motor

Drain out the oil as described in the Operating Instructions for the pump.

Then place the pump on the side with the oil level glass of the oil box.

Disassemble the pump's base (1/15).

Disassemble the fan cowl (1/7) (2 or 4 bolts respectively).

Unscrew the tie rods (1/8).

Evenly lift out the electric motor.

Lift out the sleeve of the shaft sealing ring (1/3) (with the aid of a magnet, for example).

Remove the coupling sleeves (1/2) from the shaft of the motor.

Press the shaft sealing ring out of the sleeve for the shaft sealing ring.

**Caution** Do not damage the sleeve for the shaft sealing ring.

Take the stopper (1/12) and the compression spring (1/13) out of the high vacuum bearing plate (1/14).

Remove the oil pump (1/11). Place the pump module on to the high vacuum bearing plate (1/14).

**Caution** Residual oil may flow out of the high vacuum bearing plate (1/14).

## 1.2 Disassembly of Oil Box and Valves (Pumps with Gas Ballast Option)

Unscrew the 4 hex socket bolts (2/1) of the oil box (2/40).

Remove both the oil box and the seal for the oil box (2/39).

Loosen the two bolts (2/8) at the diaphragm valve (2/33). Pull out the diaphragm valve with the oil and the gas ballast pipe (2/10).

Remove the O-ring (2/32), the gas ballast orifice (2/31) as well as the non-return valve (2/30) and the compression spring (2/29).

**Caution** Do not disassemble the diaphragm valve further. Do not clean the valve in liquids.

Pull off the spring clip (2/11).

Remove the holding frame (2/13) and the internal demister (2/14).

Loosen the hex. socket bolt (2/21) and remove it together with the valve bracket (2/26).

Completely remove the exhaust valve (items 2/22 to 2/25) and the bypass valve (2/27).

Loosen the hex. socket bolt (2/16) and disassemble the gas ballast valve.

Take out the flat seals (2/17 and 2/20).

Unscrew the exhaust port (2/6) and remove the sealing ring (2/5).

Remove the cylinder head bolt (2/34) together with the washer (2/35).

Remove the bracket (2/36), the oil level glass (2/37) and the contoured seal (2/38).

### 1.3 Disassembly of Oil Box and Valves (Pumps without Gas Ballast Option)

Unscrew the 4 hex socket bolts (2/1) of the oil box (2/40).

Remove both the oil box and the seal for the oil box (2/39).

Pull off the spring clip (2/11).

Remove the holding frame (2/13) and the internal demister (2/14).

Loosen the hex. socket bolt (2/21) and remove it together with the valve bracket (2/26).

Completely remove the exhaust valve (items 2/22 to 2/25) and the bypass valve (2/27).

Unscrew the exhaust port (2/6) and remove the sealing ring (2/5).

Remove the cylinder head bolt (2/34) together with the washer (2/35).

Remove the bracket (2/36), the oil level glass (2/37) and the contoured seal (2/38).

### 1.4 Disassembly of the Pump Module

Unscrew the hex. socket bolts (3/21).

Remove the end plate (3/1) and the O-ring (3/2).

Lift off the forevacuum pot (3/3).

Remove the sealing nipple (3/4) from the forevacuum pot.

Pull off the oil guiding panel (3/14) from the high vacuum bearing plate.

Fully remove the rotor (3/5) with the vanes (3/16 to 3/20) from the high vacuum bearing plate, remove the vanes.

Remove the flat seal (3/7) from the high vacuum bearing plate.

Take the tandem valve (3/8) with the compression spring (3/9) and the spacer (3/10) out of the high vacuum bearing plate.

Unscrew the intake port (3/11) out of the high vacuum bearing plate and remove the O-ring (3/12).

Press the shaft sealing ring (3/6) out of the high vacuum bearing plate.

**Caution** Make sure that the seat for the shaft sealing ring in the high vacuum bearing plate is not damaged.

## 2 Assembly (Pumps with Gas Ballast Option)

Clean all parts, check that they are in perfect condition and replace any defective parts as required.

### 2.1 Assembly of the Pump Module

Screw the intake port (3/11) with the O-ring (3/12) into the high vacuum bearing plate.

**Caution** Slightly oil the seat of the shaft sealing ring, the bore for the tandem valve and the high vacuum pump chamber.

Press the shaft sealing ring (3/6) right up to the stop using a matching shaft sealing ring driver (see sketch 2).

Place the spacer (3/10) into the high vacuum bearing plate.

**Caution** Note the orientation, see enlarged details C and D (**D = with gas ballast**).

Insert the compression spring (3/9) into the tandem valve (3/8) and insert it fully into the bore in the high vacuum bearing plate.

Place the flat seal (3/7) on to the high vacuum bearing plate.

Insert the high vacuum vane (3/16), slightly oiled with the guide pin (3/17) and compression spring (3/18) into the rotor (3/5).

Insert the complete rotor into the high vacuum bearing plate (3/13).

Press the sealing nipple (3/4) into the forevacuum pot (3/3) (see sketch 3, page 21).

Fit the forevacuum pot on to the high vacuum bearing plate.

Push the oil guiding panel (3/14) on.

**Caution** The sealing nipple (3/4) must be located above the tandem valve (3/8).  
When fitting, the forevacuum pot must not be turned as otherwise there is the danger that the sealing nipple might be damaged or even forced out. To maintain the position, a screw may be screwed in.

Provide the forevacuum vane (3/19) with a bezel (see sketch 4, page 21) and insert it with the guide pin (3/20) and the compression spring (3/18), slightly oiled into the rotor.

Place the O-ring (3/2) into the forevacuum pot.

Fit the end plate (3/1) and bolt home with the hex. socket bolts (3/21) (torque 5.5 Nm,  $\pm 10\%$ ).

---

## **2.2 Assembly of the Gas Ballast Valve**

Place the flat seal (2/20) into the high vacuum bearing piece (2/15). Slightly oil the gas ballast valve (2/19) and push on the cap of the gas ballast valve (2/18).

Insert the assembled parts of the gas ballast valve into the bore in the high vacuum bearing piece provided for this purpose.

Insert the flat seal (2/17) and mount the gas ballast valve with the hex. socket bolt (2/16) (torque = 11 Nm)

The gas ballast valve should be fitted so that the letters "GB" point in the direction of the oil box.

### **2.1.1 Option**

#### ***Fitting of the Gas Ballast Valve with Knurled Screw***

Lay the sealing ring (2/43) into the HV bearing piece (2/15). Insert the joined parts of the gas ballast valve (knurled screw and spring) into the bore in the HV bearing piece provided for this purpose, and screw tight.

## **2.3 Assembly of Exhaust and Bypass Valves**

Insert the bypass valve (2/27) into the valve seat of the forevacuum pot (2/28), see view A for correct orientation.

Assemble sealing element (2/25), spring (2/24) and stroke restrictor (2/23) and insert the thus assembled parts into the valve seat of the forevacuum pot (2/28).

Position the valve holder (2/22) on the stroke restrictor (2/23).

Fit the valve bracket (2/26) and tighten it with the hex. socket bolt (2/21) (torque = 5.5 Nm).

## **2.4 Assembly of the Diaphragm Valve**

### **2.4.1 Assembly of the Non-return Valve**

Insert the non-return-valve (2/30) into the conical compression spring (2/29) and insert this together with the gas ballast orifice (2/31) into the hole in the end piece.

Insert the O-ring (2/32).

**Caution** Make especially sure that the non-return valve (2/30) has been fitted in the correct orientation.

### **2.4.2 Full Assembly**

Oil the 4 new rubber inserts (2/9) and insert these into the holes provided.

Oil the oil and gas ballast pipe (2/10) at the ends.

Insert both pipes into the rubber inserts in the diaphragm valve (2/33).

Insert the pre-assembled diaphragm valve with the pipes into the end piece (2/12) and tighten it with the 2 hex. socket bolts (2/8) (torque = 5.5 Nm).

## **2.5 Assembly of the Internal Demister**

Place the internal demister (2/14) in the holding frame (2/13) and position it above the exhaust and bypass valves so that the spring clip (2/11) rests - when fitted - against the center console of the holding frame.

The holding frame (2/13) must be pushed right against the stop on the forevacuum pot (2/28) in the direction of the high vacuum bearing plate (2/15).

Fit the spring clip (2/11) using the securing ring pliers.

## **2.6 Assembly of the Oil Box**

Place the seal for the oil box (2/39) into the groove in the oil box, see enlarged detail B.

Fit the oil box (2/40) and tighten with four hex. socket bolts (2/1) with washers (2/2) (torque = 5.5 Nm).

---

## 3 Assembly

### *(Pumps without Gas Ballast Option)*

Clean all parts, check that they are in perfect condition and replace any defective parts as required.

#### 3.1 Assembly of the Pump Module

Screw the intake port (3/11) with the O-ring (3/12) into the high vacuum bearing plate.

**Caution** Slightly oil the seat of the shaft sealing ring, the bore for the tandem valve and the high vacuum pump chamber.

Press the shaft sealing ring (3/6) right up to the stop using a matching shaft sealing ring driver (see sketch 2, page 2).

Place the spacer (3/10) into the high vacuum bearing plate.

**Caution** Note the orientation, see enlarged details C and D (**C = without gas ballast**).

Insert the compression spring (3/9) into the tandem valve (3/8) and insert it fully into the bore in the high vacuum bearing plate.

Place the flat seal (3/7) on to the high vacuum bearing plate.

Insert the high vacuum vane (3/16), slightly oiled with the guide pin (3/17) and compression spring (3/18) into the rotor (3/5).

Insert the complete rotor into the high vacuum bearing plate (3/13).

Press the sealing nipple (3/4) into the forevacuum pot (3/3) (see sketch 3, page 21).

Fit the forevacuum pot on to the high vacuum bearing plate.

Push the oil guiding panel (3/14) on.

**Caution** The sealing nipple (3/4) must be located above the tandem valve (3/8).  
When fitting, the forevacuum pot must not be turned as otherwise there is the danger that the sealing nipple might be damaged or even forced out. To maintain the position, a screw may be screwed in.

Provide the forevacuum vane (3/19) with a bezel (see sketch 4, page 21) and insert it with the guide pin (3/20) and the compression spring (3/18), slightly oiled into the rotor.

Place the O-ring (3/2) into the forevacuum pot.

Fit the end plate (3/1) and bolt home with the hex. socket bolts (3/21) (torque 5.5 Nm,  $\pm 10\%$ ).

#### 3.2 Assembly of Exhaust and Bypass Valves

Insert the bypass valve (2/27) into the valve seat of the forevacuum pot (2/28), see view A for correct orientation.

Assemble sealing element (2/25), spring (2/24) and stroke restrictor (2/23) and insert the thus assembled parts into the valve seat of the forevacuum pot (2/28).

Position the valve holder (2/22) on the stroke restrictor (2/23).

Fit the valve bracket (2/26) and tighten it with the hex. socket bolt (2/21) (torque = 5.5 Nm).

#### 3.3 Assembly of the Internal Demister

Place the internal demister (2/14) in the holding frame (2/13) and position it above the exhaust and bypass valves so that the spring clip (2/11) rests - when fitted against the center console of the holding frame.

The holding frame (2/13) must be pushed right against the stop on the forevacuum pot (2/28) in the direction of the high vacuum bearing plate (2/15).

Fit the spring clip (2/11) using the securing ring pliers.

#### 3.4 Assembly of the Oil Box

Place the seal for the oil box (2/39) into the groove in the oil box, see enlarged detail B.

Fit the oil box (2/40) and tighten with four hex. socket bolts (2/1) with washers (2/2) (torque = 5.5 Nm).

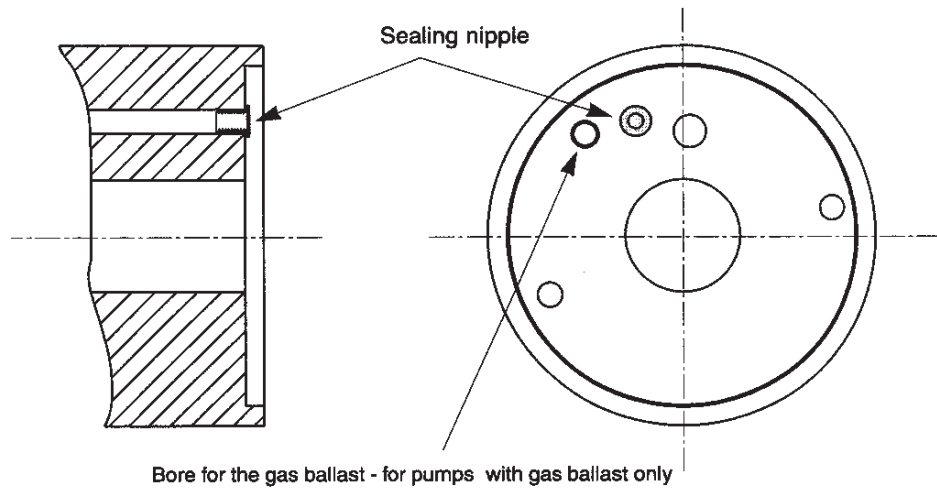

Sketch 3 Position of the sealing nipple and the bore for the gas ballast

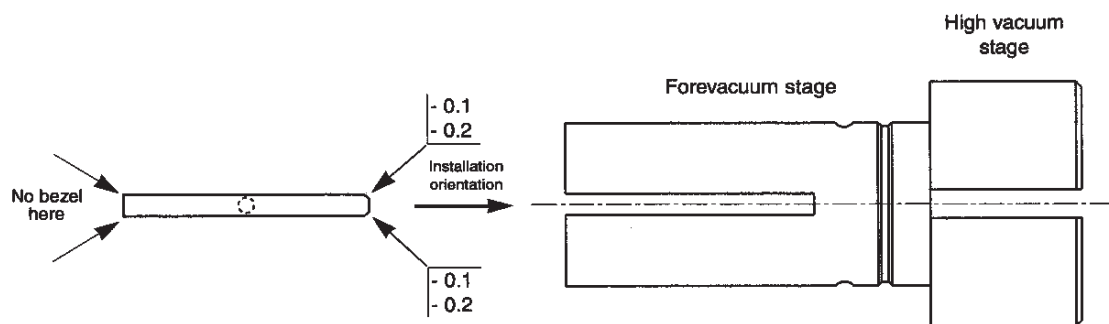

Sketch 4 How to provide the bezel on the forevacuum vanes

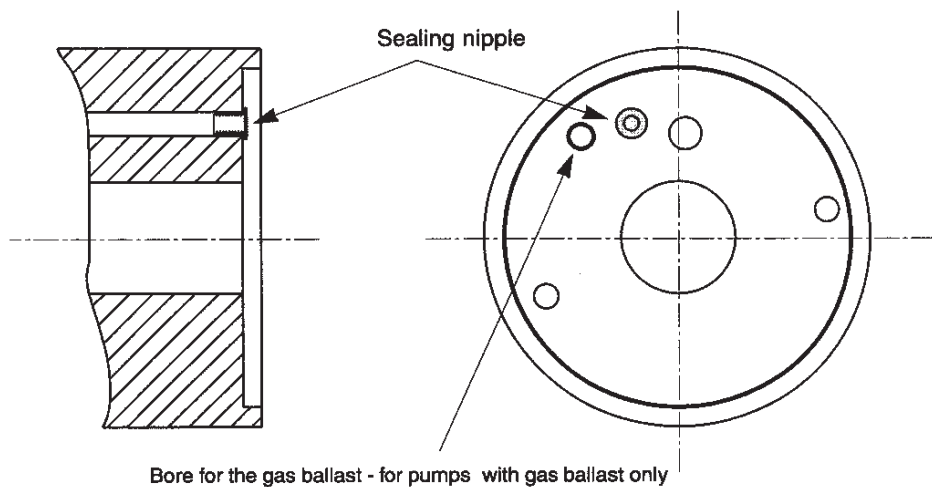

Sketch 3 Position of the sealing nipple and the bore for the gas ballast

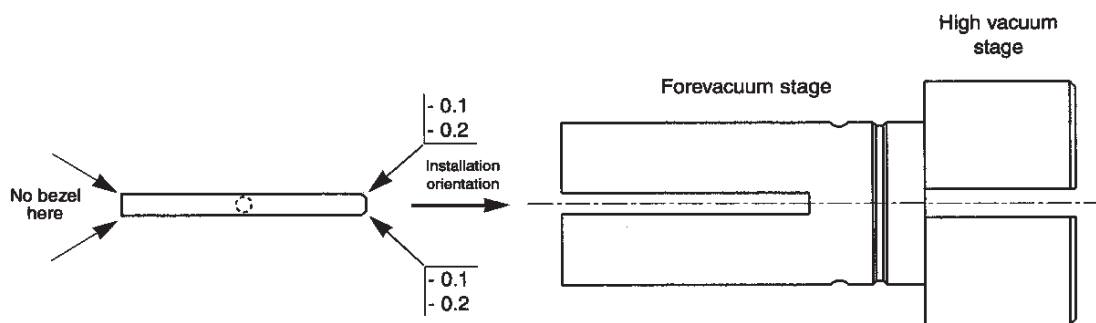

Sketch 4 How to provide the bezel on the forevacuum vanes

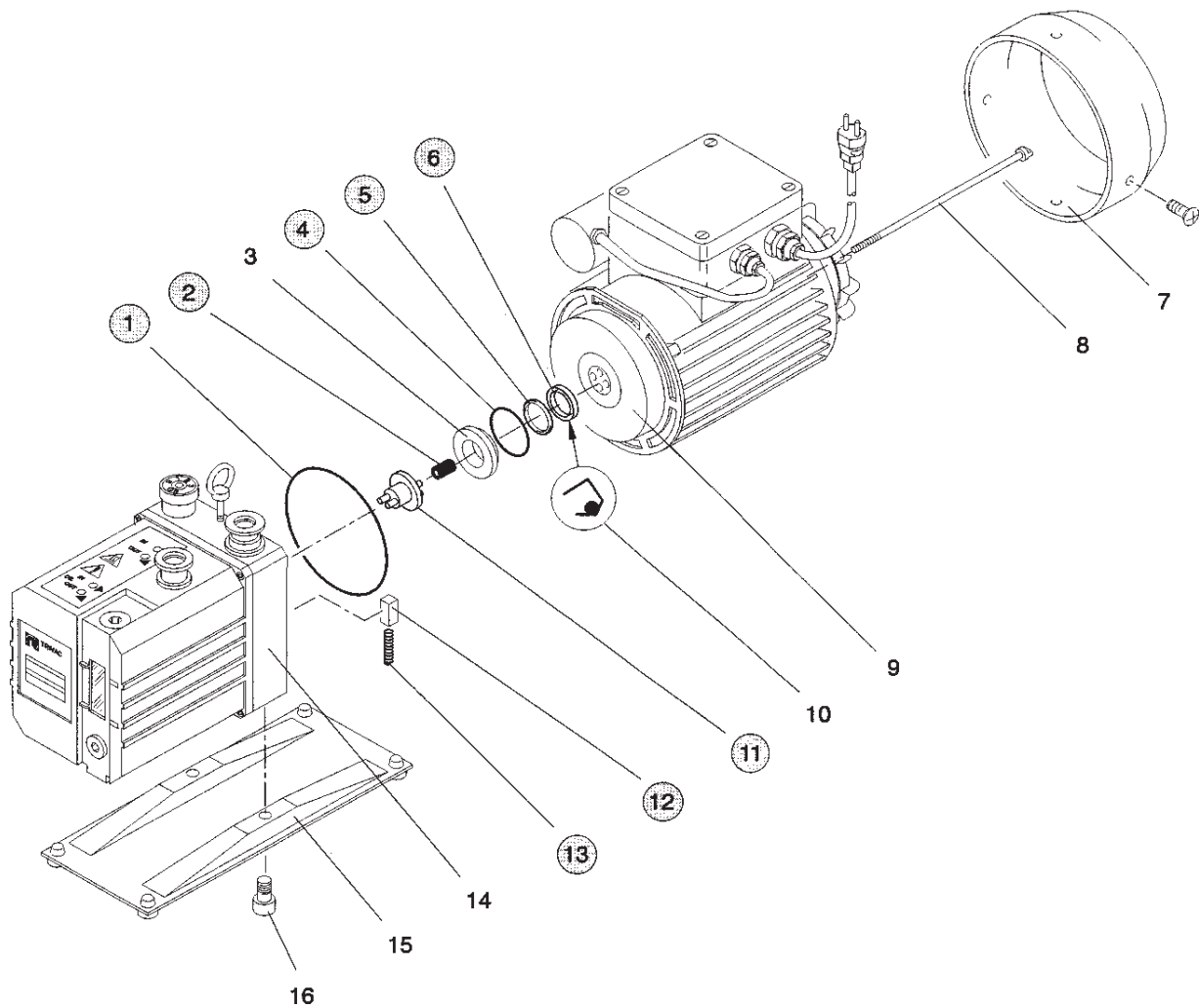

**Key to Fig. 1**

- |                             |                                       |
|-----------------------------|---------------------------------------|
| 1 O-ring                    | 9 A-bearing plate                     |
| 2 Coupling sleeve           | 10 Position of the shaft sealing ring |
| 3 Shaft sealing ring sleeve | 11 Oil pump                           |
| 4 O-ring                    | 12 Stopper                            |
| 5 Spacing disk              | 13 Compression spring                 |
| 6 Shaft sealing ring        | 14 High vacuum bearing plate          |
| 7 Fan cowl                  | 15 Pump's base                        |
| 8 Tie rods (4x)             | 16 Hex. socket bolt                   |

⊙ - Parts included in the complete kit

Fig. 1 Complete kit (for D 1.2 E - D 2.5 E)

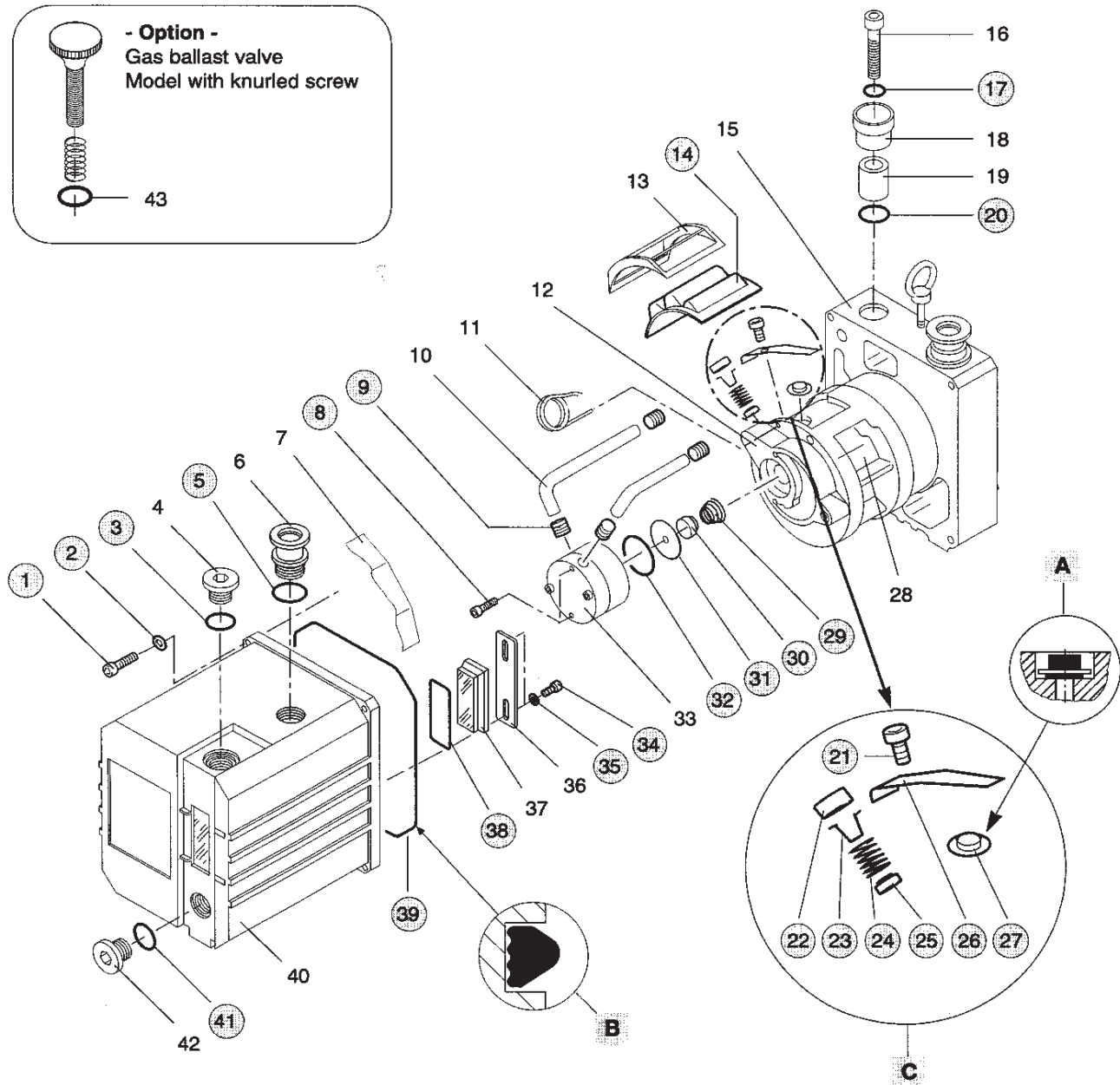
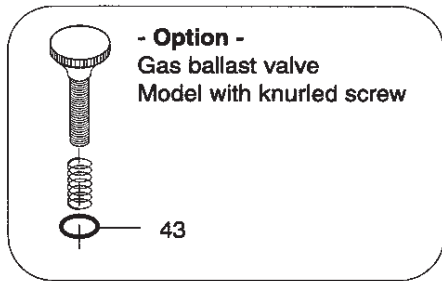

**Key to Fig. 2**

- |  |                              |                          |
|--|------------------------------|--------------------------|
| 1 Hex. socket bolt                     | 15 High vacuum bearing plate | 30 Non-return valve      |
| 2 Washer                               | 16 Hex. socket bolt          | 31 Gas ballast - orifice |
| 3 Sealing ring                         | 17 Flat seal                 | 32 O-ring                |
| 4 Oil-fill plug                        | 18 Gas ballast valve - cap   | 33 Diaphragm valve       |
| 5 Sealing ring                         | 19 Gas ballast valve         | 34 Cylinder head bolt    |
| 6 Exhaust port                         | 20 Flat seal                 | 35 Washer                |
| 7 Guide panel                          | 21 Hex. socket bolt          | 36 Holding panel         |
| 8 Hex. socket bolt                     | 22 Valve holder              | 37 Oil level glass       |
| 9 Rubber insert (4x)                   | 23 Stroke restrictor         | 38 Contoured seal        |
| 10 Oil or gas ballast pipe             | 24 Compression spring        | 39 Seal for the oil box  |
| 11 Spring clip                         | 25 Sealing element           | 40 Oil box               |
| 12 End plate                           | 26 Valve bracket             | 41 Sealing ring          |
| 13 Holding frame for internal demister | 27 Bypass valve              | 42 Oil drain plug        |
| 14 Internal demister                   | 28 Forevacuum pot            | 43 Sealing ring          |
|  | 29 Compression spring        |                          |

**Enlarged views**

- A** - Position of the bypass valve  
**B** - Seal for the oil box  
**C** - Components of the valves

Fig. 2 Complete kit for D 2.5 E, (D 1.2 E similar)

○ - Parts included in the complete kit for the D 2.5 E  
(the parts for the gas ballast are not included in the kit for the D 1.2 E)

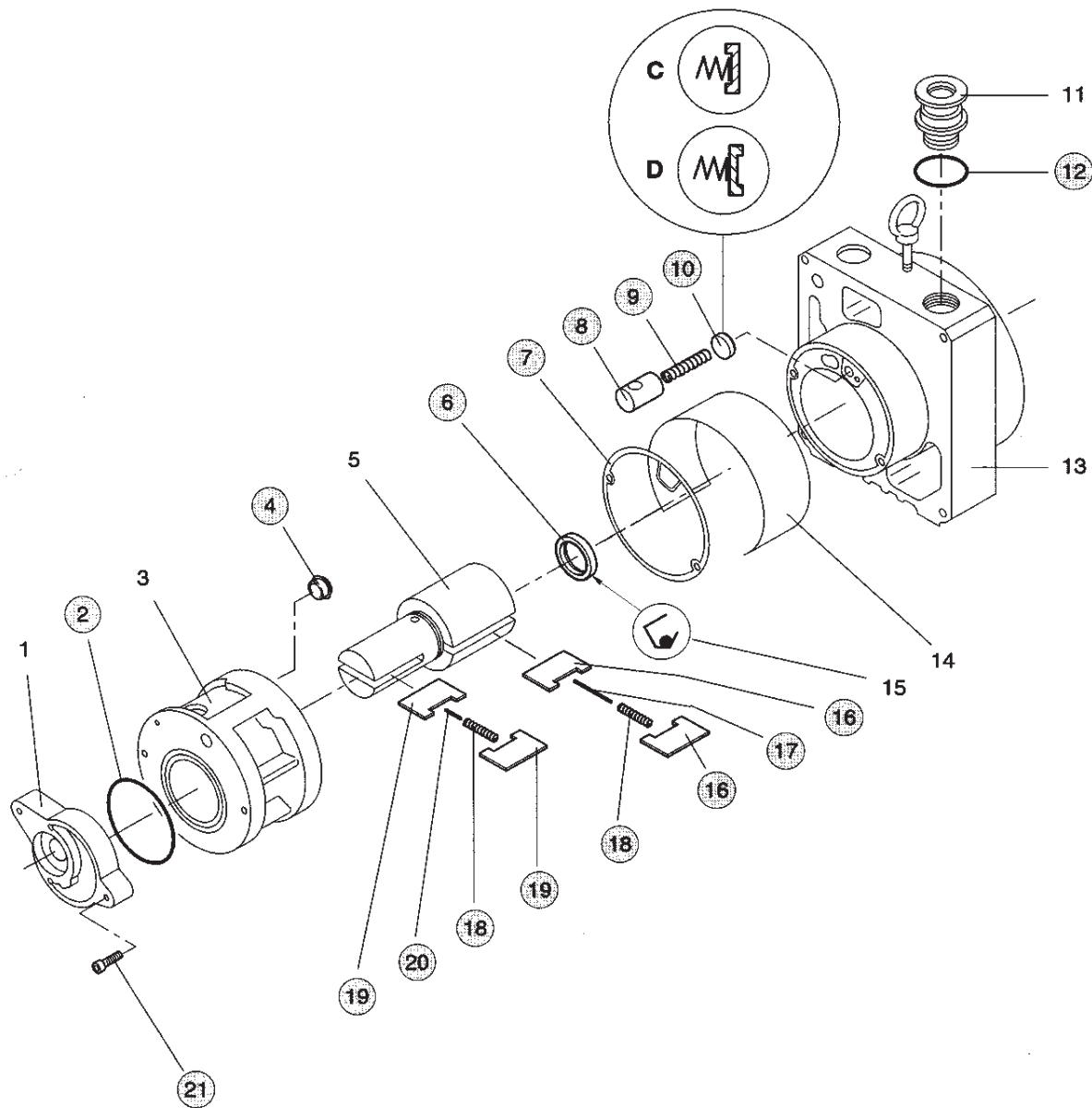

**Key to Fig. 3**

- |                      |                                |
|----------------------|--------------------------------|
| 1 End plate          | 12 O-ring                      |
| 2 O-ring             | 13 High vacuum bearing piece   |
| 3 Forevacuum pot     | 14 Oil guiding panel           |
| 4 Sealing nipple     | 15 Position/shaft sealing ring |
| 5 Rotor              | 16 Vane (HV)                   |
| 6 Shaft sealing ring | 17 Guide pin                   |
| 7 Flat seal          | 18 Compression spring          |
| 8 Tandem valve       | 19 Vane (FV)                   |
| 9 Compression spring | 20 Guide pin                   |
| 10 Spacer            | 21 Hex. socket bolt            |
| 11 Intake port       |                                |

**Enlarged views**

- C** - without gas ballast  
**D** - with gas ballast

● - Parts included in the complete kit

Fig. 3 Complete kit (for D 1.2 E - D 2.5 E)

## 5 Torque for the Bolts

Bolts at...	Fig. / Item	Quantity	Torque in Nm ( $\pm 10\%$ )
Diaphragm valve	2/8	2	5.5
Oil box	2/1	4	5.5
Gas ballast valve	2/16	1	11
Valve bracket	2/21	1	5.5
Pump's base	1/16	4	5
Tie rods	1/8	4	4
End plate	3/21	2	5.5

## 6 Overview on the Maintenance and Repair Kits

	Description	Maintenance/repair interval
<b>Maintenance kit 1</b> for TRIVAC D 1.2 - 16 E	<b>Simple maintenance for:</b> - Oil separator (internal demister) - Seal for the oil box	<b>1/year</b>
<b>Maintenance kit 2</b> for TRIVAC D 1.2 - 16 E	<b>Full maintenance for:</b> - Oil separator (internal demister) - All seals - Wearing parts	<b>3 years</b>
<b>Repair kit 1</b> for TRIVAC D 1.2 - 16 E	<b>Simple repair kit for:</b> - Sealing of the motor side, as well as exchange of wearing parts, coupling sleeves and compression spring oil pump	<b>as required</b>
<b>Repair kit 2</b> for TRIVAC D 1.2 - 16 E	<b>Simple repair kit for:</b> - Valves - Oils separator - Seal for the oil box	<b>as required</b>
<b>Repair kit 3</b> for TRIVAC D 1.2 - 16 E	<b>Complete repair kit for:</b> - Exchanging the oil separator (int. demister) - Exchange of all seals - Exchange of wearing parts	<b>as required</b>

We reserve the right to alter the design or any data given in these Operating Instructions. The illustrations are not binding.